

## LEDILSTAR-L for Lighting Ostar® LE W EXX

- Use with Ostar® LE W Exx series of white LED modules
- **Patented** system for creating a homogeneous, round light pattern without traces of light from single chips (mixing of light inside the lens)
- Lensmaterial optical grade PC (polycarbonate) with high UV and temperature resistance (130°C/260°F)

LEDILSTAR-L-S

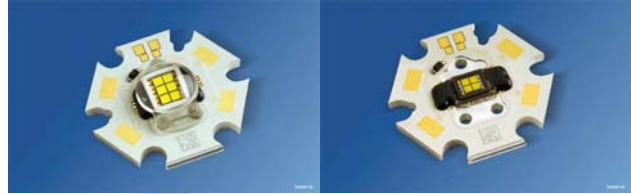

- Extremely high optical efficiency, >80%, despite of strong mixing of light and large light source
- No lens holder. Fastening to heat sink
  - o with a few glue drops or
  - o 2 screws or
  - o by clamping
- Diameter 35 mm (MR11 size)
- Easy build of a complete luminaire using LEDILSTAR, Ostar® and heat sink
- Mechanical CAD models available upon request
- Both lens types have the same outer dimensions, which allow a cross use of them in the same lighting fixture.

LEDILSTAR-L-W

## LENS TYPES

NAME	ORDERING CODE	FWHM Angle, LE W E2A	FWHM Angle, LE W E2B	FWHM Angle, LE W E3A	FWHM Angle, LE W E3B
LEDILSTAR lighting SPOT	LEDILSTAR-L-S	±6°	±8°	±6°	±8°
LEDILSTAR lighting WIDE	LEDILSTAR-L-W	±16°	±18°	±16°	±18°

© Ledil Oy – PRELIMINARY - Subject to change without prior notice

## MEASUREMENT DATA & PHOTOGRAPHS

LEDILSTAR-L-S

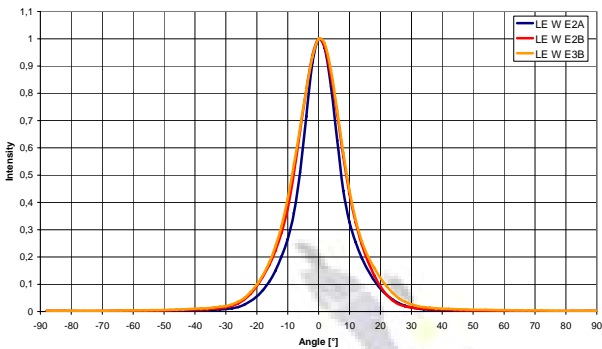

LEDILSTAR-L-W

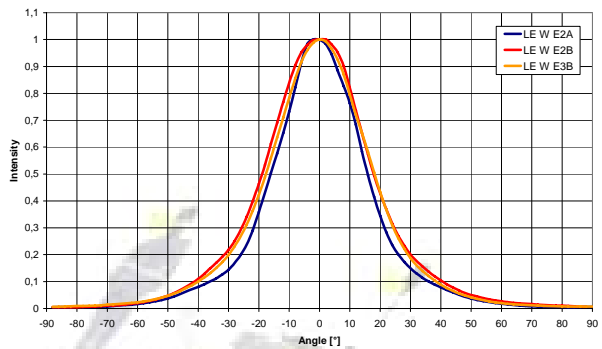

All measurements done at Osram Opto Semiconductors GmbH in Regensburg, Germany.

## DIMENSIONS & ASSEMBLY

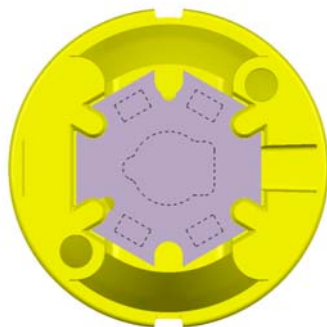
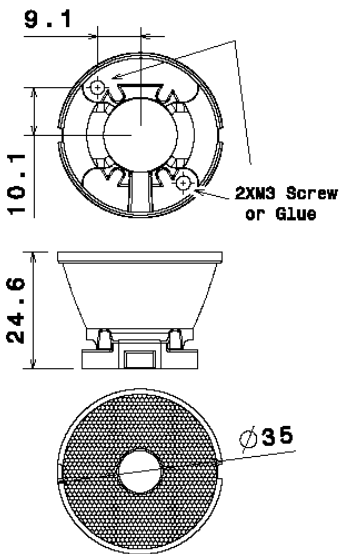

Position of Ostar



Screwing of lens

© Ledil Oy – PRELIMINARY - Subject to change without prior notice